



AMERICAN
CONTROL
ELECTRONICS

RGM Series

USER MANUAL

RGM400-1.5
RGM400-10

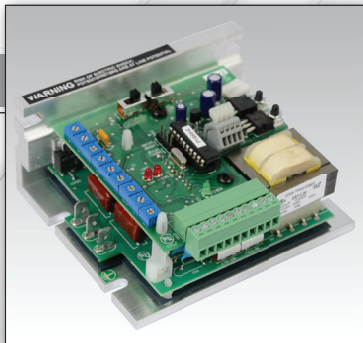

Dear Valued Consumer:

Congratulations on your purchase of the **RGM Series** drive. This User Manual was created for you to get the most out of your new device and assist with the initial setup. Please visit www.americancontrolelectronics.com to learn more about our other drives.

Thank you for choosing **American Control Electronics!**

© 2012 American Control Electronics®. All rights reserved.

No part of this manual may be reproduced or transmitted in any form without written permission from American Control Electronics®. The information and technical data in this document are subject to change without notice. American Control Electronics® and its divisions make no warranty of any kind with respect to this material, including, but not limited to, the implied warranties of its merchantability and fitness for a given purpose. American Control Electronics® and its divisions assume no responsibility for any errors that may appear in this manual and make no commitment to update or to keep current the information in this manual.

Safety First!

SAFETY WARNINGS



Text in gray boxes denote important safety tips or warnings. Please read these instructions carefully before performing any of the procedures contained in this manual.

- **DO NOT INSTALL, REMOVE, OR REWIRE THIS EQUIPMENT WITH POWER APPLIED.** Have a qualified electrical technician install, adjust and service this equipment. Follow the National Electrical Code and all other applicable electrical and safety codes, including the provisions of the Occupational Safety and Health Act (OSHA), when installing equipment.
- Reduce the chance of an electrical fire, shock, or explosion by using proper grounding techniques, over-current protection, thermal protection, and enclosure. Follow sound maintenance procedures.



It is possible for a drive to run at full speed as a result of a component failure. AMERICAN CONTROL ELECTRONICS® (ACE) strongly recommends the installation of a master switch in the main power input to stop the drive in an emergency.

Circuit potentials are at 115 VAC or 230 VAC above earth ground. Avoid direct contact with the printed circuit board or with circuit elements to prevent the risk of serious injury or fatality. Use a non-metallic screwdriver for adjusting the calibration trim pots. Use approved personal protection equipment and insulated tools if working on this drive with power applied.

Table of Contents

Section 1. Regenerative Drives	1
Section 2. Specifications	2
Section 3. Dimensions.....	3
Section 4. Installation.....	5
Mounting	5
Heat Sinking	6
Speed Adjust Potentiometer.....	7
Wiring.....	8
Shielding Guidelines.....	8
Line Fusing	9
Connections.....	11
Section 5. Operation.....	18
Before Applying Power	18
Select Switches	19
Input Voltage Select.....	19
Armature Voltage Select.....	20
Feedback Select	20
Startup.....	21
Starting and Stopping Methods	22
Line Starting and Stopping	22
Regenerative Braking to Zero Speed (INHIBIT Terminals).....	23
Regenerative Decel to Zero Speed (RB1 and RB2 Terminals) ...	24
Regenerative Decel to Minimum Speed	25
Coast to Zero Speed (ENABLE Terminals)	26
Section 6. Calibration	28
Minimum Speed (MIN SPD)	29
Maximum Speed (MAX SPD)	29
Forward Torque (FWD TQ)	30
Reverse Torque (REV TQ)	31
IR Compensation (IR COMP)	32
Forward Acceleration (FWD ACC)	34
Reverse Acceleration (REV ACC).....	34
Deadband (DB)	35

Tachogenerator (TACH).....	36
Section 7. Application Notes	43
FWD-REV and FWD-STOP-REV Switch	37
Multiple Fixed Speeds	38
Adjustable Speeds Using Potentiometers In Series.....	39
Independent Adjustable Speeds.....	40
Independent Forward and Reverse Speeds	41
FWD-REV Switch with End-of-Travel Limit Switches.....	42
RUN/JOG Switch - Inhibit Connection	43
RUN/JOG Switch - Potentiometer Connection	44
Leader-Follower Application	45
Section 8. Troubleshooting.....	46
Before Applying Power	46
Section 9. Accessory Parts.....	49
Notes	50
Unconditional Warranty.....	53

List of Tables

Table 1	Recommended Line Fuse Sizes	10
---------	-----------------------------------	----

List of Figures

Figure 1	Four Quadrant Operation	1
Figure 2	RGM400-1.5 & RGM400-10 Dimensions.....	3
Figure 3	HSK-0001 Dimensions.....	4
Figure 4	Speed Adjust Potentiometer	7
Figure 5	Quick-Disconnect Terminal Block	12
Figure 6	Cage Clamp Terminal Block.....	12
Figure 7	Power and Motor Connections (Bottom Board).....	14
Figure 8	Speed Adjust Potentiometer Connections.....	15
Figure 9	Analog Input Signal Connections.....	17
Figure 10	Select Switches (bottom board)	19
Figure 11	Select Switches (top board)	20
Figure 12	INHIBIT Settings	23
Figure 13	RUN/STOP Switch	24
Figure 14	Run/Decelerate to Minimum Speed Switch	25
Figure 15	ENABLE Settings.....	26
Figure 16	INHIBIT/ENABLE Terminal TB503 and JP502 Locations	27
Figure 17	Recommended FWD TQ, REV TQ and IR COMP Settings	33
Figure 18	Deadband Settings	35
Figure 19	FWD-REV Switch.....	37
Figure 20	FWD-STOP-REV Switch.....	37
Figure 21	Multiple Fixed Speeds	38
Figure 22	Adjustable Speeds Using Potentiometers in Series.....	39
Figure 23	Independent Adjustable Speeds.....	40
Figure 24	Independent Forward and Reverse Speeds with a FWD-REV Switch	41
Figure 25	Independent Forward and Reverse Speeds with a FWD-STOP-REV Switch.....	41
Figure 26	FWD-REV Switch with End-of-Travel Limit Switches.....	42
Figure 27	RUN/JOG Switch - Connection to Inhibit.....	43
Figure 28	RUN/JOG Switch - Connection to Speed Adjust Pot	44
Figure 29	Leader-Follower Application	45

Section 1. Regenerative Drives

Most non-regenerative, variable speed, DC drives control current flow to a motor in one direction. The direction of current flow is the same direction as the motor rotation. Non-regenerative drives operate in Quadrant I, and also in Quadrant III if the drive is reversible (see Figure 1). Motors must stop before reversing direction. Unless dynamic braking is used, non regenerative drives cannot decelerate a load faster than coasting to a lower speed.

Regenerative drives operate in two additional quadrants: Quadrant II and Quadrant IV. In these quadrants, motor torque is in the opposite direction of motor rotation.

This allows regenerative drives to reverse a motor without contactors or switches, to control an overhauling load, and to decelerate a load faster than it would to coast to a lower speed.

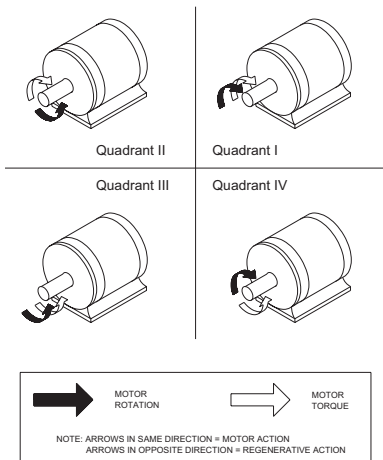

Figure 1. Four Quadrant Operation

Section 2. Specifications

<i>Model</i>	<i>Maximum Armature Current (ADC)</i>	<i>HP Range with 90 VDC Motor</i>	<i>HP Range with 180 VDC Motor</i>	<i>Enclosure</i>
RGM400-1.5	1.5	1/20 - 1/8	1/10 - 1/4	Chassis
RGM400-10*	10.0	1/8 - 1	1/4 - 2	Chassis

- * Heat sink kit part number HSK-0001 must be used when the continuous output is over 5 amps.

AC Line Voltage	115/230 VAC ± 10% 50/60 Hz, single phase
DC Armature Voltage <i>with 115 VAC Line Voltage</i> <i>with 230 VAC Line Voltage</i>	0 - 90 VDC 0 - 180 VDC
Acceleration Time Range	0.5 - 6 seconds
Deceleration Time Range	0.5 - 6 seconds
Analog Input Voltage Range (Signal must be isolated; S0 to S2)	0 to ± 10 VDC
Input Impedance (S0 to S2)	30K ohms
Form Factor	1.37 at base speed
Load Regulation	1% base speed or better
Speed Range	60:1
Vibration	0.5G maximum (0 - 50 Hz) 0.1G maximum (> 50 Hz)
Safety Certifications	UL/cUL Listed Equipment, File # E132235
Ambient Temperature Range	10°C - 55°C

Section 3. Dimensions

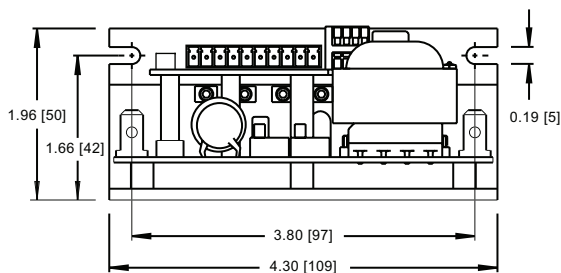
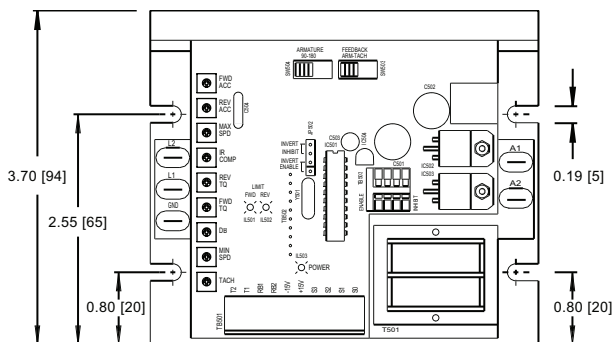

ALL DIMENSIONS IN INCHES [MILLIMETERS]

Figure 2. RGM400-1.5 & RGM400-10 Dimensions

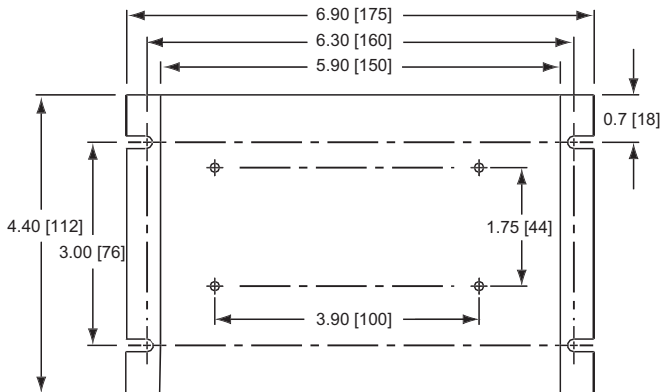

ALL DIMENSIONS IN INCHES [MILLIMETERS]

Figure 3. HSK-0001 Dimensions

Section 4. Installation



Do not install, rewire, or remove this control with input power applied. Failure to heed this warning may result in fire, explosion, or serious injury. Make sure you read and understand the Safety Precautions on page i before attempting to install this product.

Mounting

- Drive components are sensitive to electrostatic discharge. Avoid direct contact with the circuit board. Hold the drive by the chassis or heat sink only.
- Protect the drive from dirt, moisture, and accidental contact.
- Provide sufficient room for access to the terminals and calibration trim pots.
- Mount the drive away from heat sources. Operate the drive within the specified ambient operating temperature range.
- Prevent loose connections by avoiding excessive vibration of the drive.
- Mount the drive with its board in either a horizontal or vertical plane. Six 0.19" (5 mm) wide slots in the chassis accept #8 pan head screws. Fasten either the large base or the narrow flange of the chassis to the subplate.
- The chassis should be earth grounded.

Heat Sinking

The RGM series drive RGM400-10 requires an additional heat sink when the continuous armature current is above 5 amps. Use ACE heat sink kit part number HSK-0001. All other chassis drives have sufficient heat sinking in their basic configuration. Use a thermally conductive heat sink compound (such as Dow Corning® 340 Heat Sink Compound) between the chassis and the heat sink surface for optimum heat transfer.

Speed Adjust Potentiometer



Be sure that the potentiometer tabs do not make contact with the potentiometer's body. Grounding the input will cause damage to the drive.

Mount the speed adjust potentiometer through a 0.38 in. (10 mm) hole with the hardware provided (Figure 5). Install the circular insulating disk between the panel and the 10K ohm speed adjust potentiometer.

Twist the speed adjust potentiometer wires to avoid picking up unwanted electrical noise. If the speed adjust potentiometer wires are longer than 18 in. (46 cm), use shielded cable. Keep the speed adjust potentiometer wires separate from power leads (L1, L2, A1, A2).

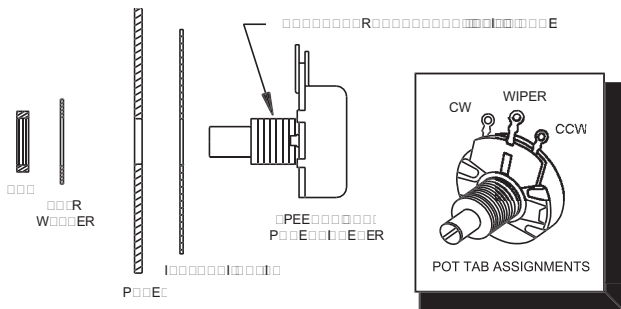

Figure 4. Speed Adjust Potentiometer

Wiring



Do not install, rewire, or remove this control with input power applied. Failure to heed this warning may result in fire, explosion, or serious injury.

Circuit potentials are at 115 or 230 VAC above ground. To prevent the risk of injury or fatality, avoid direct contact with the printed circuit board or with circuit elements.

Do not disconnect any of the motor leads from the drive unless power is removed or the drive is disabled. Opening any one motor lead while the drive is running may destroy the drive.

- Use 18 - 24 AWG wire for logic wiring. Use 14 - 16 AWG wire for AC line and motor wiring.

Shielding Guidelines



Under no circumstances should power and logic level leads be bundled together. Induced voltage can cause unpredictable behavior in any electronic device, including motor controls.

As a general rule, AMERICAN CONTROL ELECTRONICS® (ACE) recommends shielding of all conductors. If it is not practical to shield power conductors, ACE recommends shielding all logic-level leads. If shielding of all logic-level leads is not practical, the user should twist all logic leads with themselves to minimize induced noise.

It may be necessary to earth ground the shielded cable. If noise is produced by devices other than the drive, ground the shield at the drive end. If noise is generated by a device on the drive, ground the shield at the end away from the drive. Do not ground both ends of the shield.

Shielding Guidelines (continued)

If the drive continues to pick up noise after grounding the shield, it may be necessary to add AC line filtering devices, or to mount the drive in a less noisy environment.

Logic wires from other input devices, such as motion controllers and PLL velocity controllers, must be separated from power lines in the same manner as the logic I/O on this drive.

Line Fusing

ACE drives should be fused for protection. Use fast acting fuses rated for 250 VAC or higher and 150% of maximum armature current. Fuse HOT L1 only when the line voltage is 115 VAC. Fuse both L1 and L2 when the line voltage is 230 VAC. Table 1 on page 10 lists the recommended line fuse sizes.

Table 1. Recommended Line Fuse Sizes

<i>90 VDC Motor Horsepower</i>	<i>180 VDC Motor Horsepower</i>	<i>Maximum DC Armature Current (amps)</i>	<i>AC Line Fuse Size (amps)</i>
<i>1/20</i>	<i>1/10</i>	<i>0.5</i>	<i>1</i>
<i>1/15</i>	<i>1/8</i>	<i>0.8</i>	<i>1.5</i>
<i>1/8</i>	<i>1/4</i>	<i>1.5</i>	<i>3</i>
<i>1/6</i>	<i>1/3</i>	<i>1.7</i>	<i>3</i>
<i>1/4</i>	<i>1/2</i>	<i>2.5</i>	<i>5</i>
<i>1/3</i>	<i>3/4</i>	<i>3.5</i>	<i>8</i>
<i>1/2</i>	<i>1</i>	<i>5.0</i>	<i>10</i>
<i>3/4</i>	<i>1 ½</i>	<i>7.5</i>	<i>15</i>
<i>1</i>	<i>2</i>	<i>10</i>	<i>15</i>

ACE offers fuse kits. See Section 9: Accessories and Replacement parts for fuse kit part numbers.

Connections



Do not install, rewire, or remove this control with input power applied. Failure to heed this warning may result in fire, explosion, or serious injury.

ACE strongly recommends the installation of a master power switch in the voltage input line, as shown in Figure 7 (page 14). The switch contacts should be rated at a minimum of 200% of motor nameplate current and 250 volts.

Quick-Disconnect Terminal Block

The quick-disconnect terminal block is composed of a 10-pin header block and 10-screw terminal plug (Figure 5 on page 12). To use the quick-disconnect terminal block:

1. Carefully pull terminal plug from header block.
2. With a small flat-head screwdriver, turn terminal plug screw counterclockwise to open wire clamp.
3. Insert stripped wire into the large opening in front of the plug.
4. Turn the terminal plug screw clockwise to clamp the wire.
5. Repeat steps 2–4 for each terminal until all connections are made.
6. Insert plug into header until securely fastened.

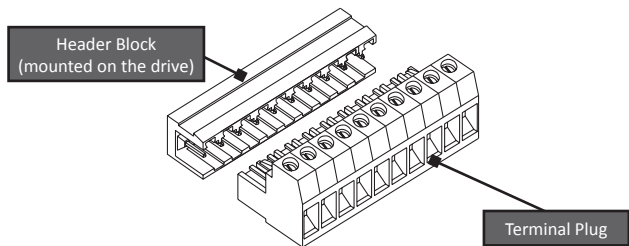

Figure 5. Quick-Disconnect Terminal Block

Cage-Clamp Terminal Block

RGM series drives use a cage-clamp terminal block for the enable and inhibit connections. To connect a wire to the cage-clamp terminal block (see Figure 6), use a small screwdriver to press down on the lever arm. Insert a wire stripped approximately 0.25 inches (6 mm) into the opening in front of the terminal block. Release the lever arm to clamp the wire.

Press down on the lever arm using a small screwdriver.

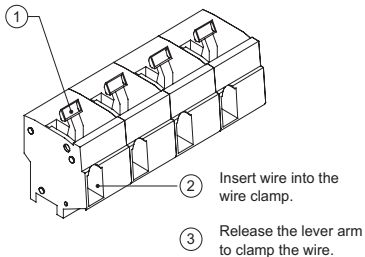

Figure 6. Cage Clamp Terminal Block

Power Input

Connect the AC line power leads to terminals L1 and L2. ACE recommends the use of a single-throw, double-pole master power switch. The switch should be rated at a minimum of 250 volts and 200% of motor current. Refer to Figure 7 on page 14.

Motor

ACE drives supply motor voltage from A1 and A2 terminals, where A1 is positive with respect to A2. If the motor does not spin in the desired direction, remove power and reverse the A1 and A2 connections.

Connect a DC motor to terminals A1 and A2 as shown in Figure 7 on page 14. Ensure that the motor voltage rating is consistent with the drive's output voltage.

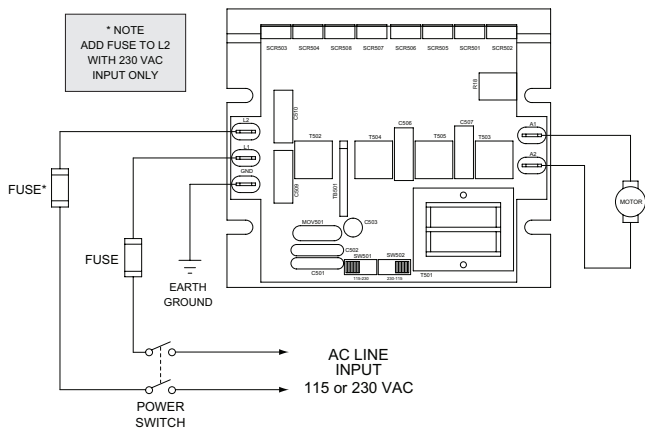

Figure 7. Power and Motor Connections (Bottom Board)

Speed Adjust Potentiometer Connection

Use a 10K ohm, 1/4 W potentiometer for speed control. The motor can operate in one direction (unidirectional) or two directions (bidirectional) depending on how the speed adjust potentiometer is connected to the drive.

For unidirectional operation in the forward direction, connect the speed adjust potentiometer as shown in Figure 8(a).

For unidirectional operation in the reverse direction, connect the speed adjust potentiometer as shown in Figure 8(b).

For bidirectional operation, connect the speed adjust potentiometer as shown in Figure 8(c). The motor does not operate when the potentiometer is in the center position. Turning the potentiometer clockwise (CW) from the center position causes the motor to rotate in the forward direction, while turning the potentiometer counterclockwise (CCW) causes rotation in the reverse direction.

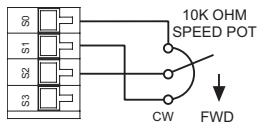

Figure 8(a). Unidirectional Forward

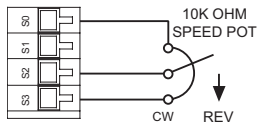

Figure 8(b). Unidirectional Reverse

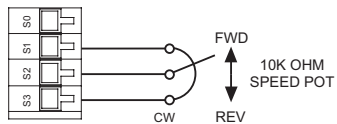

Figure 8(c). Bidirectional

Tachogenerator Feedback

Using tachogenerator feedback improves speed regulation from approximately 1% of motor base speed to approximately 0.1% of motor base speed. Use tachogenerators rated from 7 VDC per 1000 RPM to 50 VDC per 1000 RPM. Connect the tachogenerator to terminals T1 and T2 of terminal block TB501. The polarity is positive (+) for T1 and negative (-) for T2 when the motor is running in the forward direction. Place SW503 in the TACH position. The TACH trim pot must be adjusted prior to operating with tachogenerator feedback. Refer to the Calibration section for instructions on calibrating the TACH trim pot.

+15 and -15



Do not short the +15 and -15 terminals for any reason. Shorting these terminals will damage the drive.

RGM series drives can supply a regulated +15 and -15 VDC signal (each sourcing 20 mA maximum) with respect to RB1 or T1, to isolated, external devices. These voltage supply terminals are located on terminal block TB502.

Enable, Inhibit, and Regen Brake Connections

See the “Starting and Stopping Methods” section on pages 22 through 27 for a detailed description of the Enable, Inhibit, and Regen Braking (RB1, RB2) connections.

Analog Input Signal (RGM400 models)

Instead of using a speed adjust potentiometer, the drive may be wired to follow an analog input voltage signal that is isolated from earth ground (Figure 9). Connect the signal common (-) to RB1. Connect the signal reference (+) to S2. Make no connection to S0, S1 or S3. A potentiometer can be used to scale the analog input voltage. An interface device, such as ACE model ISO202-1, may be used to scale and isolate an analog input voltage.

An input voltage range of approximately 0 to ± 10 VDC is required to produce an armature voltage range of 0 to ± 90 VDC with a 115 VAC line, or 0 to ± 180 VDC with a 230 VAC line.

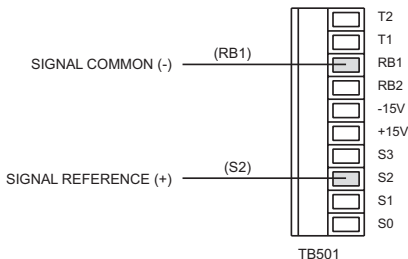

Figure 9. Analog Input Signal Connections

Section 5. Operation



Change voltage switch settings only when the drive is disconnected from AC line voltage. Make sure both switches are set to their correct position. If the switches are improperly set to a lower voltage position, the motor will not run at full voltage and may cause damage to the transformer. If the switches are improperly set to a higher voltage position, the motor will overspeed, which may cause motor damage, or result in bodily injury or loss of life.

Dangerous voltages exist on the drive when it is powered. BE ALERT. High voltages can cause serious or fatal injury. For your safety, use personal protective equipment (PPE) when operating this drive.

If the motor or drive does not perform as described, disconnect the AC line voltage immediately. Refer to the Troubleshooting section, page 43, for further assistance.

Before Applying Power

1. Verify that no foreign conductive material is present on the printed circuit board.
2. Ensure that all switches are properly set.

Select Switches

Input Voltage Select (SW501, SW502)

Set the input voltage select switches SW501 and SW502 to either 115 or 230 to match the AC line voltage. See Figure 10.

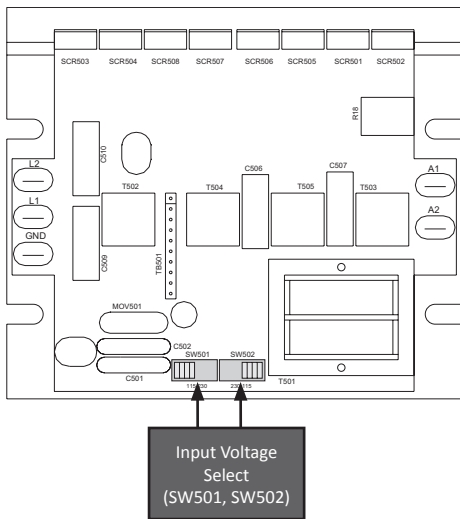

Figure 10. Select Switches (bottom board)

Armature Voltage Select (SW504)

Set the armature voltage select switch SW504 to either 90 or 180 to match the maximum armature voltage. See Figure 11.

Feedback Select (SW503)

Set the feedback select switch SW503 to either ARM for armature feedback or TACH for tachogenerator feedback. See Figure 11.

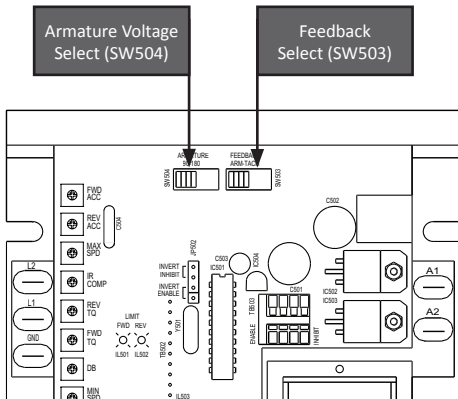

Figure 11. Select Switches (top board)

Startup

1. Turn the speed adjust potentiometer full counterclockwise (CCW) or set the input voltage or current signal to minimum.
2. Apply AC line voltage.
3. Slowly advance the speed adjust potentiometer clockwise (CW) or increase the input voltage or current signal. The motor slowly accelerates as the potentiometer is turned CW or as the input voltage or current signal is increased. Continue until the desired speed is reached.
4. Remove AC line voltage from the drive to coast the motor to a stop.

Starting and Stopping Methods



Regenerative braking, coasting to a stop, or decelerating to minimum speed is recommended for frequent starts and stops. Do not use any of these methods for emergency stopping. They may not stop a drive that is malfunctioning. Removing AC line power (both lines) is the only acceptable method for emergency stopping.

For this reason, ACE strongly recommends installing an emergency stop switch on both AC line inputs (see Figure 7 on page 14).

Frequent starting and stopping can produce high torque. This may cause damage to motors, especially gearmotors that are not properly sized for the application.

Automatic Restart Upon Power Restoration

All drives automatically run to set speed when power is applied, neither the inhibit or regenerative brake are active, and the enable is active.

Line Starting and Stopping

Line starting and stopping (applying and removing AC line voltage) is recommended for infrequent starting and stopping of a drive only. When AC line voltage is applied to the drive, the motor accelerates to the speed set by the speed adjust potentiometer or analog signal. When AC line voltage is removed, the motor coasts to a stop.

Regenerative Brake to Zero Speed (INHIBIT Terminals)

Activate the INHIBIT terminals to regeneratively brake the motor to zero speed. The inhibit bypasses both the MIN SPD trim pot and the deceleration rate set by the FWD ACC or REV ACC trim pots. Deactivate the INHIBIT terminals to accelerate the motor to set speed. See Figure 16 on page 27 for INHIBIT terminal location.

For a normally open connection, leave pins 1 and 2 open on JP502. For a normally closed connection, jumper pins 1 and 2 on JP502. Jumpers can be found in the potentiometer kit (part number KTP-0007).

Twist inhibit wires and separate them from other power-carrying wires or sources of electrical noise. Use shielded cable if the inhibit wires are longer than 18 in. (46 cm). If shielded cable is used, ground only one end of the shield to earth ground. Do not ground both ends of the shield.

INHIBIT SETTINGS

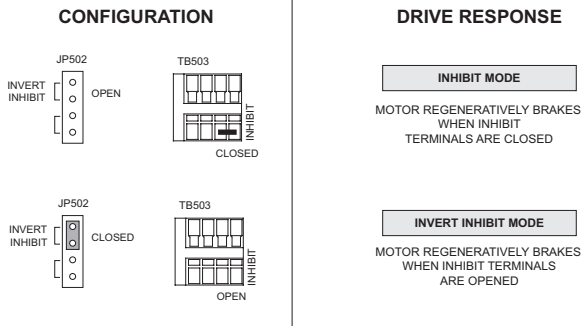

Figure 12. INHIBIT Settings

Regenerative Decel to Zero Speed (RB1 and RB2 Terminals)

Short the RB1 and RB2 terminals to regeneratively brake the motor to zero speed. See Figure 13. The RB1 and RB2 circuit follows the deceleration rate set by the FWD ACC and REV ACC trim pots. Open the RB1 and RB2 terminals to accelerate the motor to set speed.

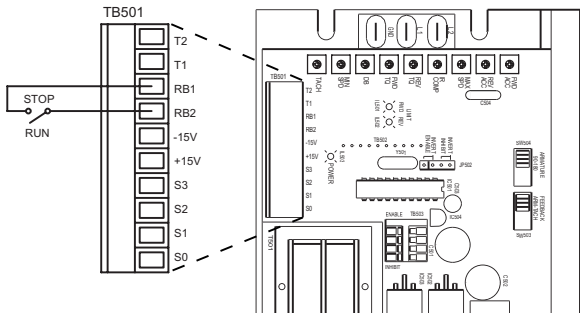

Figure 13. RUN/STOP Switch

Regenerative Decel to Minimum Speed

The switch shown in Figure 14 may be used to decelerate a motor to a minimum speed. Closing the switch between S0 and S2 decelerates the motor from set speed to a minimum speed determined by the MIN SPD trim pot setting. If the MIN SPD trim pot is set full CCW, the motor decelerates to zero speed. The REV ACC or FWD ACC trim pot setting determines the rate at which the drive decelerates, depending on the direction of deceleration. By opening the switch, the motor accelerates to set speed.

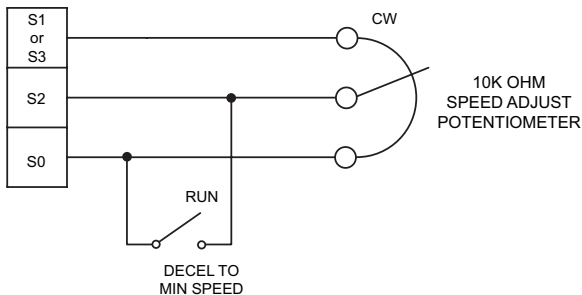

Figure 14. Run/Decelerate to Minimum Speed Switch

Coast to Zero Speed (ENABLE Terminals)

Activate the ENABLE terminals to coast the motor to zero speed. The enable bypasses both the MIN SPD trim pot and the deceleration rate set by the FWD ACC or REV ACC trim pots. Deactivate the ENABLE terminals to accelerate the motor to set speed. See Figure 16 on page 27 for ENABLE terminal location.

For a normally open connection, leave pins 3 and 4 open on JP502. For a normally closed connection, jumper pins 3 and 4 on JP502. Jumpers can be found in the potentiometer kit (part number KTP-0007).

Twist enable wires and separate them from other power-carrying wires or sources of electrical noise. Use shielded cable if the enable wires are longer than 18 in. (46 cm). If shielded cable is used, ground only one end of the shield to earth ground. Do not ground both ends of the shield.

ENABLE SETTINGS

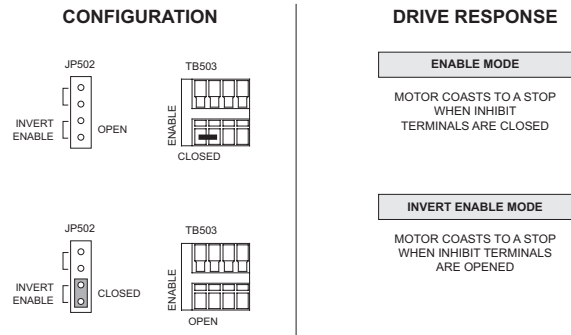

Figure 15. ENABLE Settings

INVERT INHIBIT & INVERT ENABLE
Jumper Settings (JP502)

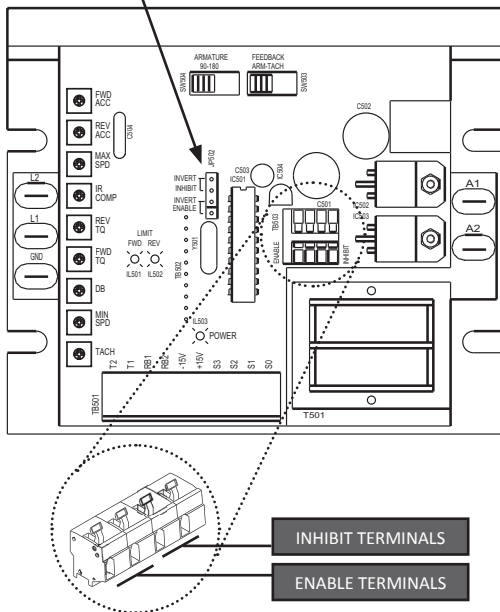

Figure 16. INHIBIT/ENABLE Terminal TB503 and JP502 Locations

Section 6. Calibration



Dangerous voltages exist on the drive when it is powered. When possible, disconnect the voltage input from the drive before adjusting the trim pots. If the trim pots must be adjusted with power applied, use insulated tools and the appropriate personal protection equipment. **BE ALERT.** High voltages can cause serious or fatal injury.

RGM series drives have user-adjustable trim pots. Each drive is factory calibrated to its maximum current rating. Readjust the calibration trim pot settings to accommodate lower current rated motors.

All adjustments increase with CW rotation and decrease with CCW rotation. Use a non-metallic screwdriver for calibration. Each trim pot is identified on the printed circuit board.

Minimum Speed (MIN SPD)

The MIN SPD setting determines the minimum motor speed in unidirectional operation when the speed adjust potentiometer or input voltage or current signal is set for minimum speed.

To calibrate the MIN SPD:

1. Set the speed adjust potentiometer or input voltage signal for minimum speed.
2. Adjust MIN SPD until the desired minimum speed is reached or is just at the threshold of rotation.

Maximum Speed (MAX SPD)

The MAX SPD setting determines the maximum motor speed in the forward and reverse direction when the speed adjust potentiometer or input voltage or current signal is set for maximum speed.

To calibrate MAX SPD:

1. Set the speed adjust potentiometer or input voltage signal for maximum speed.
2. Adjust MAX SPD until the desired maximum speed is reached.

Note: Check the MIN SPD and MAX SPD adjustments after recalibrating to verify that the motor runs at the desired minimum and maximum speed.

Forward Torque (FWD TQ)



FWD TQ can be set to 150% of motor nameplate current rating. Continuous operation beyond this rating may damage the motor. If you intend to operate beyond this rating, contact your ACE representative for assistance.

The FWD TQ setting determines the maximum torque for accelerating and driving the motor in the forward direction. To calibrate FWD TQ, refer to the recommended FWD TQ settings in Figure 17 on page 33 or use the following procedure:

1. With the power disconnected from the drive, connect a DC ammeter in series with the armature.
2. Set the FWD TQ trim pot to minimum (full CCW).
3. Set the speed adjust potentiometer (full CW) or input voltage signal to maximum forward speed.
4. Carefully lock the motor armature. Be sure that the motor is firmly mounted.
5. Apply line power. The motor should be stopped.
6. Slowly adjust the FWD TQ trim pot CW slowly until the armature current is 120% of the motor rated armature current.
7. Set the speed adjust potentiometer CCW or decrease the input voltage signal.
8. Remove line power.
9. Remove the stall from the motor shaft.
10. Remove the ammeter in series with the motor armature if it is no longer needed.

Reverse Torque (REV TQ)



REV TQ can be set to 150% of motor nameplate current rating. Continuous operation beyond this rating may damage the motor. If you intend to operate beyond this rating, contact your ACE representative for assistance.

The REV TQ setting determines the maximum torque for accelerating and driving the motor in the forward direction. To calibrate REV TQ, refer to the recommended REV TQ settings in Figure 17 on page 33 or use the following procedure:

1. With the power disconnected from the drive, connect a DC ammeter in series with the armature.
2. Set the REV TQ trim pot to minimum (full CCW).
3. Set the speed adjust potentiometer (full CW) or input voltage signal to maximum reverse speed.
4. Carefully lock the motor armature. Be sure that the motor is firmly mounted.
5. Apply line power. The motor should be stopped.
6. Slowly adjust the REV TQ trim pot CW slowly until the armature current is 120% of the motor rated armature current.
7. Set the speed adjust potentiometer CCW or decrease the input voltage signal.
8. Remove line power.
9. Remove the stall from the motor shaft.
10. Remove the ammeter in series with the motor armature if it is no longer needed.

IR Compensation (IR COMP)

The IR COMP setting determines the degree to which motor speed is held constant as the motor load changes.

Use the following procedure to recalibrate the IR COMP:

1. Set the IR COMP trim pot to minimum (full CCW).
2. Increase the speed adjust potentiometer or input voltage signal until the motor runs at mid-speed without load (for example, 900 RPM for an 1800 RPM motor). A hand-held tachometer may be used to measure motor speed.
3. Load the motor armature to its full load armature current rating. The motor should slow down.
4. While keeping the load on the motor, rotate the IR COMP trim pot until the motor runs at the speed measured in step 2. If the motor oscillates (overcompensation), the IR COMP trim pot may be set too high (CW). Turn the IR COMP trim pot CCW to stabilize the motor.
5. Unload the motor.

See Figure 17 on page 33 for recommended IR COMP settings.

























			1 HP 90 VDC 10 ADC				2 HP 180 VDC 9.2 ADC
FWD TQ	REV TQ	IR COMP		FWD TQ	REV TQ	IR COMP	
			3/4 HP 90 VDC 7.6 ADC				1 HP 180 VDC 5 ADC
FWD TQ	REV TQ	IR COMP		FWD TQ	REV TQ	IR COMP	
			1/2 HP 90 VDC 5 ADC				3/4 HP 180 VDC 3.8 ADC
FWD TQ	REV TQ	IR COMP		FWD TQ	REV TQ	IR COMP	
			1/4 HP 90 VDC 2.7 ADC				1/2 HP 180 VDC 2.5 ADC
FWD TQ	REV TQ	IR COMP		FWD TQ	REV TQ	IR COMP	

Figure 17. Recommended FWD TQ, REV TQ and IR COMP Settings
(actual settings may vary with each application)

Forward Acceleration (FWD ACC)

The FWD ACC setting determines the time the motor takes to ramp to either a higher speed in the forward direction or a lower speed in the reverse direction, within the limits of available torque. The FWD ACC setting is factory set for its fastest forward acceleration time.

Turn the FWD ACC trim pot CW to increase the forward acceleration time, and CCW to decrease the forward acceleration time.

Reverse Acceleration (REV ACC)

The REV ACC setting determines the time the motor takes to ramp to either a higher speed in the reverse direction or a lower speed in the forward direction, within the limits of available torque. The REV ACC setting is factory set for its fastest reverse acceleration time.

Turn the REV ACC trim pot CW to increase the reverse acceleration time, and CCW to decrease the reverse acceleration time.

Deadband (DB)

The deadband trim pot determines the time that will elapse between the application of current in one direction before current is applied in the opposite direction.

The deadband trim pot affects the resistance that a motor has to changes in shaft position at zero speed. It does this by applying AC voltage to the motor armature.

Deadband is factory calibrated with the notch at approximately the 3 o'clock position for 60 Hz AC line operation. Recalibrate the deadband with the notch at the 9 o'clock position for 50 Hz AC line operation. If you hear motor noise (humming), the deadband might be set too high. Turn the deadband trim pot CCW until the motor noise ceases.

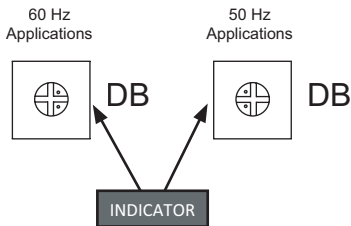

Figure 18. Deadband Settings

Tachogenerator (TACH)



Calibrate the TACH setting only when a tachogenerator is used.

The TACH setting, like IR COMP setting, determines the degree to which motor speed is held constant as the motor load changes. To calibrate the TACH trim pot:

1. Connect the tachogenerator to T1 and T2. The polarity is positive (+) for T1 and negative (-) for T2 when the motor is running in the forward direction.
2. Set the feedback select switch SW503 to ARM for armature feedback.
3. Set the speed adjust potentiometer or input voltage signal to maximum forward speed. Measure the armature voltage across A1 and A2 using a voltmeter.
4. Set the speed adjust potentiometer or input voltage signal to zero speed.
5. Set SW503 to TACH for tachogenerator feedback.
6. Set the IR COMP trim pot to full CCW.
7. Set the TACH VOLTS trim pot to full CW.
8. Set the speed adjust potentiometer or input voltage signal to maximum forward speed.
9. Adjust the TACH trim pot until the armature voltage is the same value as the voltage measured in step 3.

Check that the TACH is properly calibrated. The motor should run at the same set speed when SW503 is set to either ARM or TACH.

Section 7. Application Notes

FWD-REV and FWD-STOP-REV Switch

Use a single-pole, two-position switch with a single speed adjust potentiometer for a direction switch as shown in Figure 19. If a STOP position is desired, use a single-pole, three-position switch as shown in Figure 20. The STOP will follow the deceleration rate set by the FWD ACC and REV ACC trim pots.

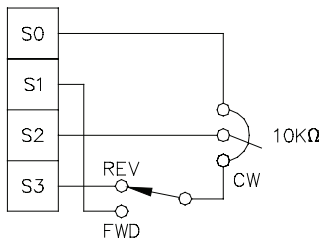

Figure 19. FWD-REV Switch

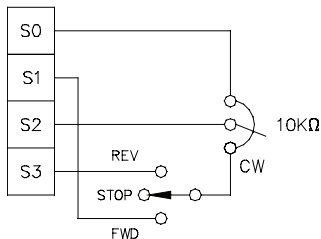

Figure 20. FWD-STOP-REV Switch

Multiple Fixed Speeds

Replace the speed adjust potentiometer with a series of resistors with a total series resistance of 10K ohms (Figure 21). Add a single pole, multi-position switch with the correct number of positions for the desired number of fixed speeds. To add a direction switch, refer to Figure 19 or Figure 20 on page 37.

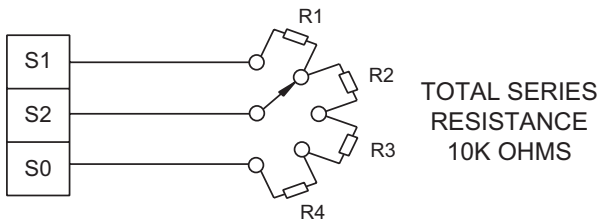

Figure 21. Multiple Fixed Speeds

Adjustable Speeds Using Potentiometers In Series

Replace the speed adjust potentiometer with a series of potentiometers with a total series resistance of 10K ohms (Figure 22). Add a single pole, multi-position switch with the correct number of positions for the desired number of fixed speeds. To add a direction switch, refer to Figure 19 or Figure 20 on page 37.

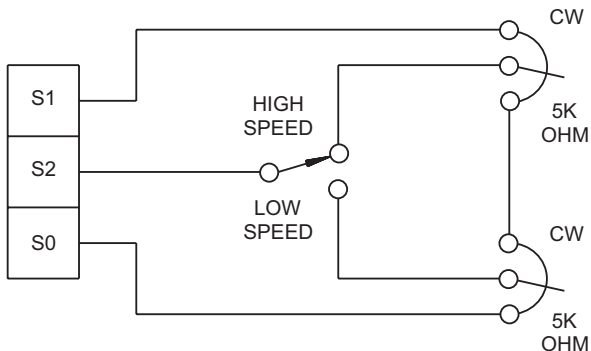

Figure 22. Adjustable Speeds Using Potentiometers In Series

Independent Adjustable Speeds

Replace the speed adjust potentiometer with a single pole, multi-position switch, and two or more potentiometers in parallel, with a total parallel resistance of 10K ohms. Figure 23 shows the connection of two independent speed adjust potentiometers that can be mounted at two separate operating stations. To add a direction switch, refer to Figure 19 or Figure 20 on page 37.

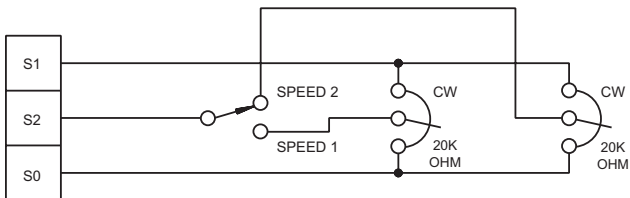

Figure 23. Independent Adjustable Speeds

Independent Forward and Reverse Speeds

Connect two speed adjust potentiometers and a single-pole, two-position switch as shown in Figure 24 to select between independent forward and reverse speeds. For a direction switch with a STOP position, use a single-pole, three-position switch as shown in Figure 25.

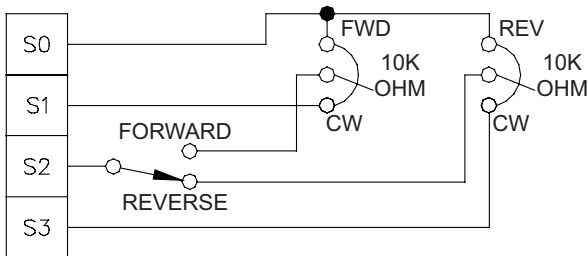

Figure 24. Independent Forward and Reverse Speeds with a FWD-REV Switch

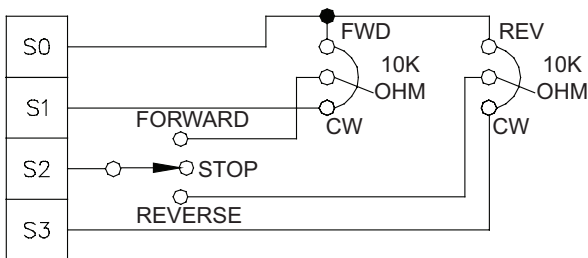

Figure 25. Independent Forward and Reverse Speeds with a FWD-STOP-REV Switch

FWD-REV Switch with End-of-Travel Limit Switches

Use a single-pole, two-position switch with a single speed adjust potentiometer for a direction switch as shown in Figure 26. Wire a normally closed limit switch in series with S1 (forward limit) and another (reverse limit) in series with S3.

If you desire any type of automatic cycling with the limit switches, use American Control Electronics switching logic board, model number LSL100-1.

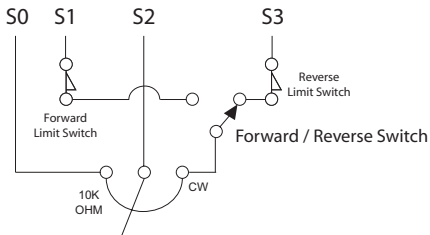

Figure 26. FWD-REV Switch with End-of-Travel Limit Switches

RUN/JOG Switch - Inhibit Connection

Using a RUN/JOG switch is recommended in applications where quick stopping is not needed and frequent jogging is required. Use a single pole, two position switch for the RUN/JOG switch, and a normally closed momentary pushbutton for the JOG pushbutton.

Connect the RUN/JOG switch and JOG pushbutton to the inhibit plug as shown in Figure 27. Set the INHIBIT for Normally Open operation, refer to pages 23 and 27. The motor coasts to a stop when the RUN/JOG switch is set to JOG. Press the JOG pushbutton to jog the motor. Return the RUN/JOG switch to RUN for normal operation.

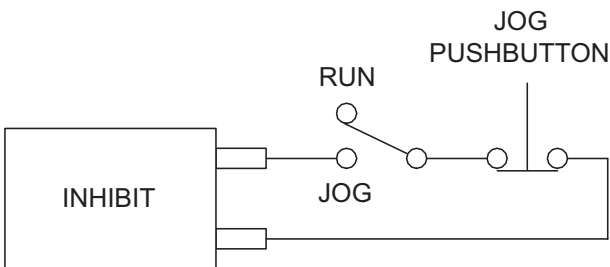

Figure 27. RUN/JOG Switch - Connection to Inhibit

RUN/JOG Switch - Potentiometer Connection

Connect the RUN/JOG switch and the JOG pushbutton as shown in Figure 28. When the RUN/JOG switch is set to JOG, the motor decelerates to minimum speed (minimum speed is determined by the MIN SPD trim pot setting). Press the JOG pushbutton to jog the motor. Return the RUN/JOG switch to RUN for normal operation. To add a direction switch, refer to Figures 19 or 20 on page 37.

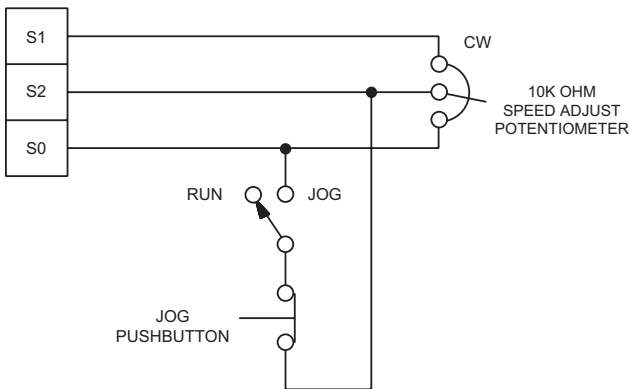

Figure 28. RUN/JOG Switch - Connection to Speed Adjust Potentiometer

Leader-Follower Application

In this application, use a ISO202-1 to monitor the speed of the leader motor (Figure 29). The ISO202-1 isolates the leader motor from the follower drive, and outputs a voltage proportional to the leader motor armature voltage. The follower drive uses this voltage reference to set the speed of the follower motor. An optional ratio potentiometer may be used to scale the ISO202-1 output voltage.

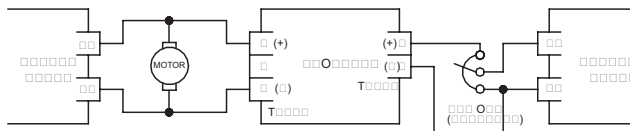

Figure 29. Leader-Follower Application

Section 8. Troubleshooting



Dangerous voltages exist on the drive when it is powered. When possible, disconnect the drive while troubleshooting. High voltages can cause serious or fatal injury.

Before Applying Power

Check the following steps before proceeding:

1. The AC line voltage must be connected to the proper terminals.
2. Check that the switch and jumper settings are correctly set.
3. The motor must be rated for the drive's rated armature voltage and current.
4. Check that all terminal block connections are correct.

For additional assistance, contact your local AMERICAN CONTROL ELECTRONICS distributor, or the factory direct:

1-800-646-2745 or FAX: 1-815-624-6960

PROBLEM	POSSIBLE CAUSE	SUGGESTED SOLUTIONS
Line fuse blows.	1. Line fuse is the wrong size.	1. Check that the line fuse is correct for the motor size.
	2. Motor cable or armature is shorted to ground.	2. Check motor cable and armature shorts.
	3. Nuisance tripping caused by a combination of ambient conditions and high-current spikes (i.e. reversing).	3. Add a blower to cool the drive components; decrease FWD TQ and REV TQ settings, or resize motor drive for actual load demand, or check for incorrectly aligned mechanical components or "jams".
Line fuse does not blow, but the motor does not run.	1. Speed adjust potentiometer or speed reference voltage is set to zero speed.	1. Increase the speed adjust potentiometer setting or speed reference voltage.
	2. Speed adjust potentiometer or speed reference is not connected to drive input properly; connections are open.	2. Check the connections to the input. Verify that the connections are not open.
	3. INHIBIT mode is active.	3. Remove the short from the INHIBIT terminals or add a short to INHIBIT terminals if INHIBIT mode is set to INVERTED.
	4. S2 is shorted to S0.	4. Remove the short.
	5. Drive is in current limit.	5. Verify that the motor is not jammed. Increase the FWD TQ or REV TQ setting if they are set too low.
	6. Drive is not receiving AC line voltage.	6. Apply AC line voltage to L1 and L2.
	7. Motor is not connected.	7. Connect the motor to A1 and A2.

PROBLEM	POSSIBLE CAUSE	SUGGESTED SOLUTIONS
Motor runs too fast.	1. MAX SPD is not calibrated.	1. Calibrate MAX SPD.
Motor will not reach the desired speed.	1. MAX SPD setting is too low.	1. Increase MAX SPD setting.
	2. IR COMP setting is too low.	2. Increase IR COMP setting.
	3. Motor is overloaded.	3. Check motor load. Resize the motor if necessary.
	4. Drive is in current limit.	4. Verify that the motor is not jammed. Increase the FWD TQ or REV TQ setting if they are set too low.
Motor pulsates or surges under load.	1. IR COMP is set too high	1. Adjust the IR COMP setting slightly CCW until the motor speed stabilizes.
	2. Motor bouncing in and out of current limit.	2. Make sure the motor is not undersized for load; adjust FWD TQ or REV TQ trim pot CW. See page 30 or 31.

Section 9. Accessories & Replacement Parts

Displays

Open Loop.....	OLD100-1
Closed Loop.....	CLD100-1

Heat sinks

Chassis.....	HSK-0001
--------------	----------

Kits

Potentiometer & Connector

10K Pot, Insulating Washer.....	KTP-0001
10K Pot, Insulating Washer, 9 Insulated Tabs	KTP-0002
9 Pin Terminal Block (included with -QDT drives).....	KTP-0003

Fuse

2 1.5 Amp 250 V 3AG Fast-blow Glass Fuses.....	KTF-0001
2 3 Amp 250 V 3AG Fast-blow Glass Fuses.....	KTF-0002
2 5 Amp 250 V 3AG Fast-blow Glass Fuses.....	KTF-0003
2 8 Amp 250 V 3AG Fast-blow Glass Fuses.....	KTF-0004
2 10 Amp 250 V 3AB Normal-blow Ceramic Fuses.....	KTF-0005
2 15 Amp 250 V 3AB Normal-blow Ceramic Fuses.....	KTF-0006

Logic Cards

Current Monitoring

5 Amps.....	CMC100-5
15 Amps.....	CMC100-20

Isolation

Uni-directional, 8 outputs.....	ISO101-8
Bi-directional, 1 output.....	ISO202-1

Notes

Notes

Notes

Unconditional Warranty

A. Warranty

American Control Electronics, referred to as “the Corporation” warrants that its products will be free from defects in workmanship and material for twelve (12) months or 3000 hours, whichever comes first, from date of manufacture thereof. Within this warranty period, the Corporation will repair or replace, at its sole discretion, such products that are returned to American Control Electronics, 14300 De La Tour Drive, South Beloit, Illinois 61080 USA.

This warranty applies only to standard catalog products, and does not apply to specials. Any returns of special controls will be evaluated on a case-by-case basis. The Corporation is not responsible for removal, installation, or any other incidental expenses incurred in shipping the product to and from the repair point.

B. Disclaimer

The provisions of Paragraph A are the Corporation’s sole obligation and exclude all other warranties of merchantability for use, expressed or implied. The Corporation further disclaims any responsibility whatsoever to the customer or to any other person for injury to the person or damage or loss of property of value caused by any product that has been subject to misuse, negligence, or accident, or misapplied or modified by unauthorized persons or improperly installed.

C. Limitations of Liability

In the event of any claim for breach of any of the Corporation’s obligations, whether expressed or implied, and particularly of any other claim or breach of warranty contained in Paragraph A, or of any other warranties, expressed or implied, or claim of liability that might, despite Paragraph B, be decided against the Corporation by lawful authority, the Corporation shall under no circumstances be liable for any consequential damages, losses, or expenses arising in connection with the use of, or inability to use, the Corporation’s product for any purpose whatsoever.

An adjustment made under warranty does not void the warranty, nor does it imply an extension of the original 12-month warranty period. Products serviced and/or parts replaced on a no-charge basis during the warranty period carry the unexpired portion of the original warranty only.

If for any reason any of the foregoing provisions shall be ineffective, the Corporation’s liability for damages arising out of its manufacture or sale of equipment, or use thereof, whether such liability is based on warranty, contract, negligence, strict liability in tort, or otherwise, shall not in any event exceed the full purchase price of such equipment.

Any action against the Corporation based upon any liability or obligation arising hereunder or under any law applicable to the sale of equipment or the use thereof, must be commenced within one year after the cause of such action arises.



www.americancontrolelectronics.com

• 14300 DE LA TOUR DRIVE • SOUTH BELOIT, IL 61080 •
• (815) 624-6915 • (815) 624-6965 fax •

Document Number - MAN-0009, Rev 0 - March 2012

© 2011 AMERICAN CONTROL ELECTRONICS®